

5-7 Analog Input Terminals

5-7-1 SRT2-AD04 Analog Input Terminal

Note Do not connect the Analog Input Terminal to any of the following incompatible Master Units or incorrect data may be transmitted.

PLC	Incompatible Master Units	Compatible Master Units
CS-series, C200HX/ C200HG/ C200HE-(Z)E, and C200HS	C200HW-SRM21	C200HW-SRM21-V1
CS-series	---	CS1W-SRM21
CJ-series	---	CJ1W-SRM21
CQM1	CQM1-SRM21	CQM1-SRM21-V1
SRM1 (Integrated with CPU Unit)	SRM1-C0□ SRM1-C0□-V1	SRM1-C0□-V2
CPM2C-S (Integrated with CPU Unit)	---	All Units

The Analog Input Terminal is also incompatible with the following Master Units:

3G8B3-SRM0□ CompoBus/S VME Board
C200PC-ISA□2-SRM SYSMAC Board

Specifications

The following tables show the ratings and input specifications for the SRT2-AD04.

General Specifications

Item	Specification
Model	SRT2-AD04
Input points	4, 3, 2, or 1 points (switchable using DIP switch) (4, 3, 2, or 1 words are allocated to the Master.)
Power supply type	Network power supply
Communications power supply voltage	14 to 26.4 V DC (Power can be supplied from the communications cable.)
Current consumption	Communications power: 100 mA max.
Noise immunity	±1.5 kVp-p with a pulse width of 0.1 to 1 μs and a rise time of 1 ns (via impulse noise simulator)
Vibration resistance	10 to 55 Hz, 1.0-mm double amplitude
Shock resistance	200 m/s ²
Dielectric strength	500 V AC for 1 minute (between insulated circuits)
Insulation resistance	20 MΩ min. at 250 V DC (between insulated circuits)
Ambient temperature	Operating: -10 to 55°C Storage: -25 to 65°C
Ambient humidity	Operating: 25% to 85% (with no condensation) Storage: 25% to 85% (with no condensation)
Operating environment	No corrosive gases
Mounting method	M4 screws or 35-mm DIN track mounting
Mounting strength	50 N Track direction: 10 N
Terminal strength	Pulling: 50 N
Weight	Approx. 120 g

Input Specifications

Item	Specification		
	Voltage input	Current input	
Input signal range	0 to 5 V 1 to 5 V 0 to 10 V -10 to 10 V	0 to 20 mA 4 to 20 mA	
	Input signal range settings for Input 0 and Input 1 are shared. Input signal range settings for Input 2 and Input 3 are shared.		
Max. signal input	±15 V	±30 mA	
Input impedance	1 MΩ min.	Approx. 250 Ω	
Resolution	1/6000 (Full scale)		
General precision	25°C	±0.3%FS	±0.4%FS
	0 to 55°C	±0.6%FS	±0.8%FS
Conversion time	1 ms/point (4 ms/4 points, 3 ms/3 points, 2 ms/2 points, or 1 ms/1 point)		
AD conversion output data	Binary data -10 to 10 V: Full scale F448 to 0 to 0BB8 Hex Other: Full scale 0000 to 1770 Hex		
Averaging Function	Can be set (with DIP switch)		
Burnout detection function	Available		
Insulation method	Between analog input and communications line: Photo-coupler Between each analog input signal: Non-insulated		

Slave Components

The following diagram shows the main components of the SRT2-AD04 Analog Input Terminal. The functions of these components are described below.

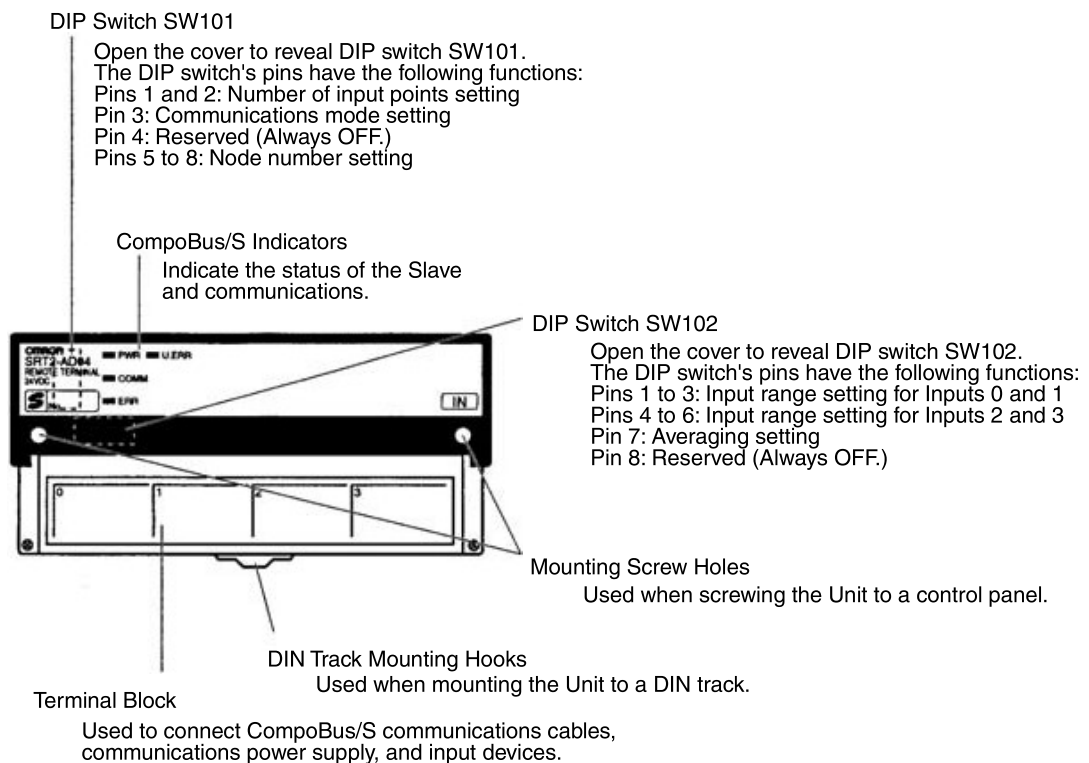

Indicators

The following table shows the meaning of the indicators.

Indicator	Status	Meaning
PWR (green)	ON	The communications power supply is ON.
	OFF	The communications power supply is OFF.
COMM (yellow)	ON	Normal communications
	OFF	A communications error has occurred or the Unit is in standby status.
ERR (red)	ON	A communications error has occurred.
	OFF	Normal communications or the Unit is in standby status.
U.ERR (red)	ON	An error has occurred in the Unit.
	OFF	Normal communications or the Unit is in standby status.

DIP Switches

Always turn OFF the Slave before changing DIP switch settings.

SW101

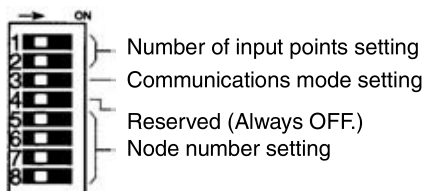

Pin 1	Pin 2	Number of input points setting
OFF	OFF	4 points (Factory setting)
OFF	ON	3 points (Inputs 0 to 2 valid)
ON	OFF	2 points (Inputs 0 and 2 valid)
ON	ON	1 point (Input 0 valid)

Pin 3	Communications mode setting
OFF	High-speed Communications Mode (Factory setting)
ON	Long-distance Communications Mode

Pin 4	Always set to OFF.

Note Make sure that the communications mode of the Slave is the same as that of the Master Unit. If the communications modes are not the same, normal communications with the Master Unit will not be possible. The operating status of the Slave can be verified with LED indicators. Refer to 6-5-1 *Indicators* for details.

Node Number Setting

Set the node number with pins 5 through 8, as shown in the following table.

Node number	Pin 5 (8)	Pin 6 (4)	Pin 7 (2)	Pin 8 (1)
0	OFF	OFF	OFF	OFF
1	OFF	OFF	OFF	ON
2	OFF	OFF	ON	OFF
3	OFF	OFF	ON	ON
4	OFF	ON	OFF	OFF
5	OFF	ON	OFF	ON
6	OFF	ON	ON	OFF
7	OFF	ON	ON	ON
8	ON	OFF	OFF	OFF
9	ON	OFF	OFF	ON
10	ON	OFF	ON	OFF
11	ON	OFF	ON	ON
12	ON	ON	OFF	OFF
13	ON	ON	OFF	ON
14	ON	ON	ON	OFF
15	ON	ON	ON	ON

A single Analog Input Terminal is allocated 64 points, 48 points, 32 points, or 16 points. Points are assigned as shown in the following table. Note that when a CQM1 Master Unit is used in 4-point mode, the Analog Input Terminal cannot be connected.

Allocated points	Node number setting	Node number actually used
64 points (4 inputs)	Odd	Node number setting – 1 to node number setting + 6
	Even	Node number setting to node number setting + 7
48 points (3 inputs)	Odd	Node number setting – 1 to node number setting + 4
	Even	Node number setting to node number setting + 5
32 points (2 inputs)	Odd	Node number setting – 1 to node number setting + 2
	Even	Node number setting to node number setting + 3
16 points (1 input)	Odd	Node number setting – 1 to node number setting
	Even	Node number setting to node number setting + 1

SW102

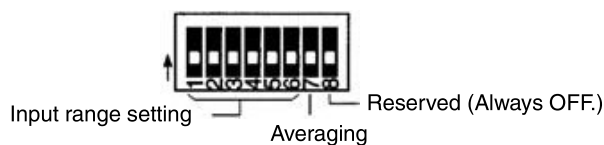

Pin 1	Pin 2	Pin 3	Range setting for Inputs 0 and 1
Pin 4	Pin 5	Pin 6	Range setting for Inputs 2 and 3
OFF	OFF	OFF	0 to 5 V (Factory setting)
ON	OFF	OFF	1 to 5 V
OFF	ON	OFF	0 to 10 V
ON	ON	OFF	-10 to 10 V
OFF	OFF	ON	4 to 20 mA
ON	OFF	ON	0 to 20 mA

Do not set to any values but those given above.

Pin 7	Averaging
OFF	No averaging (Factory setting)
ON	With averaging (8-time moving average)

Pin 8	Always set to OFF.
-------	--------------------

Note Input range settings for Input 0 and Input 1 are shared, and those for Input 2 and Input 3 are shared. An example is shown below.

Input 0 and Input 1: 4 to 20 mA (Pins 1, 2, 3 = OFF, OFF, ON)

Input 2 and Input 3: 1 to 5 V (Pins 4, 5, 6 = ON, OFF, OFF)

Internal Circuits

The following diagram shows the internal circuits for the SRT2-AD04.

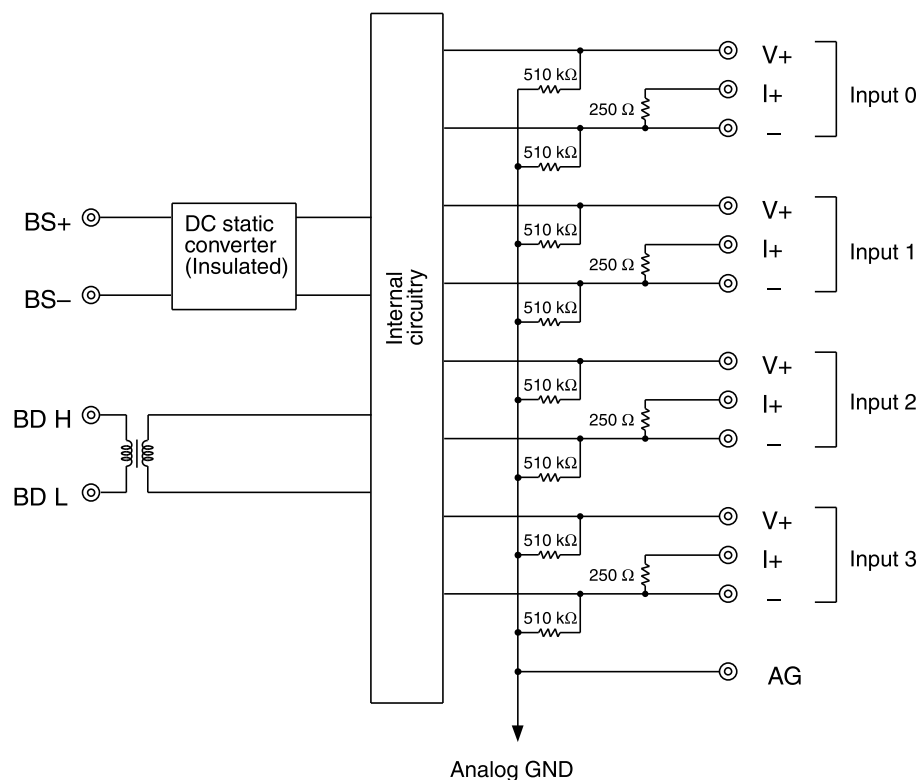

Terminal Block

Install the following M3 crimp terminals on the signal wires and connect them to the terminal block.



Note Tighten the terminal block screws to the specified tightening torque of 0.5 N·m.

The following diagram shows the terminal block for the SRT2-AD04.

BD H	BS +	AG	V0+	I0+	V1+	I1+	V2+	I2+	V3+	I3+
BD L	BS -	NC	AG	0-	NC	1-	NC	2-	NC	3-

Note For current input, short terminals V+ and I+.

Wiring

Wire the connector terminals of the Analog Input Terminal as shown below according to voltage input or current input.

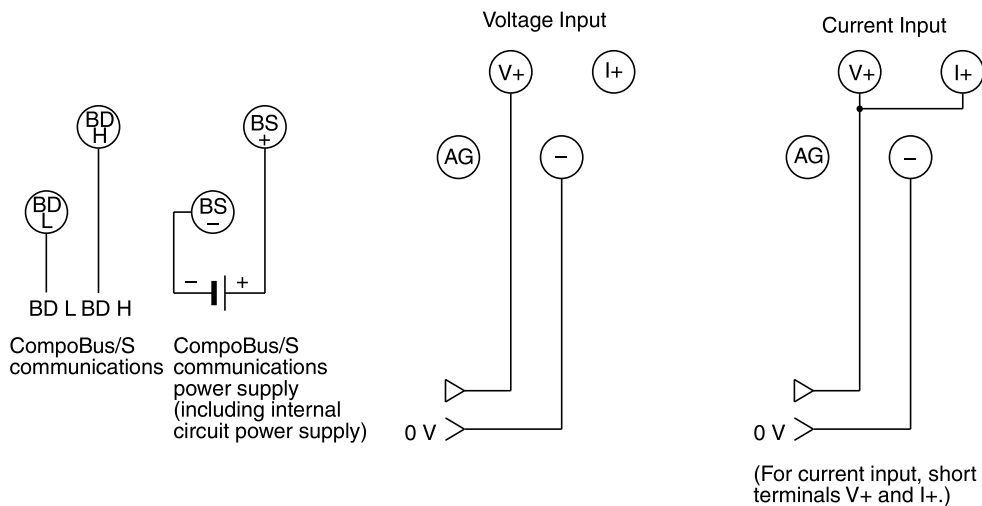

For current input, short terminals V+ and I+. Use the short circuiting fitting provided to accomplish this.

Input Range and Conversion Data

The analog data that is input will be converted to digital values according to the input range.

Note If the input range is surpassed, the AD conversion data will be fixed at the upper or lower limit.

-10 to 10 V

Voltages between -10 V and 10 V correspond to F448 to 0BB8 Hex (-3000 to 3000). The range of data that can be converted is F31C to 0CE4 Hex (-3300 to 3300). When voltage is negative, it is expressed as 2's complement (16