

TE200A
Power controllers

Two-phase control
of three-phase loads

User manual

©Copyright Eurotherm Automation 1997

All rights reserved. All reproduction or transmission in any form or using any procedure (electronic or mechanical, including photocopying or recording) without written authorisation from EUROTHERM AUTOMATION is strictly prohibited.

EUROTHERM AUTOMATION has made every effort to ensure that the specification given in this manual is as accurate and up to the minute as possible. However, in order to maintain our 'leading edge', it may be necessary to make certain changes or omissions to our specification. We cannot be held responsible for any damage to persons or property or for any financial loss or costs arising from this.

TE200A**USER MANUAL**

CONTENTS		Page
	EUROPEAN DIRECTIVES	iv
	CE MARKING AND SAFETY	iv
	ELECTROMAGNETIC COMPATIBILITY (EMC)	iv
	DECLARATION OF CE CONFORMITY	v
	PRECAUTIONS	vi
CHAPTER 1	IDENTIFYING THE CONTROLLERS	1-2
	GENERAL INTRODUCTION TO THE TE200A SERIES	1-2
	TECHNICAL SPECIFICATION	1-5
	PRODUCT CODE	1-7
	EXAMPLE OF PRODUCT CODE	1-8
	SERIAL NUMBER LABELS	1-8
CHAPTER 2	INSTALLATION	2-2
	INSTALLATION - SAFETY	2-2
	DIMENSIONAL DETAILS	2-3
	MOUNTING DETAILS	2-5
CHAPTER 3	WIRING	3-2
	WIRING - SAFETY	3-2
	POWER WIRING	3-3
	USER TERMINAL BLOCKS	3-5

	Page
CHAPTER 4	
CONFIGURATION	4-2
CONFIGURATION - SAFETY	4-2
DRIVER BOARD CONFIGURATION	4-3
CHAPTER 5	
OPERATION	5-2
THYRISTOR FIRING MODES	5-2
CONTROL OPERATION	5-6
CHAPTER 6	
COMMISSIONING PROCEDURE	6-2
COMMISSIONING PROCEDURE - SAFETY	6-2
CHECKING THE CHARACTERISTICS	6-3
POWERING UP THE CONTROLLER	6-4
CHAPTER 7	
MAINTENANCE	7-2
FUSES	7-2
SERVICING	7-5
TOOLS	7-5



EUROPEAN DIRECTIVES

CE MARKING AND SAFETY

TE200A products carry the CE mark in compliance with the essential requirements of the European Low Voltage Directive 73/23/EEC of 19/2/73 (amended by the Directive 93/68/EEC of 22/7/93).

For safety reasons, TE200A products installed and used in compliance with this User Manual meet the essential requirements of the European Low Voltage Directive.

ELECTROMAGNETIC COMPATIBILITY (EMC)

For an industrial environment only, must not be used in domestic environments.

Eurotherm certifies that TE200A products, installed and used in compliance with these Instructions, meet the following EMC standards and enable the system which incorporates them to comply with the EMC Directive, as far as the TE200A products are concerned.

EMC test standards

Immunity	Generic standard	: EN 50082-2
	Test standards	: EN 61000-4-2, EN 61000-4-4, ENV 50140, ENV 50141 ENV 50204
Emission	Generic standard	: EN 50081-2
	Test standard	: EN 55011 Class A
	Product standard	: IEC 1800-3 (second environment)

Internal EMC filters

EMC filters are incorporated in the TE200A to reduce conducted emission in accordance with the corresponding test standard.

EMC Guide

In order to help you reduce the effects of electromagnetic interference depending on the product installation, Eurotherm can supply you with the 'Electromagnetic Compatibility' Installation Guide (ref: HA 025464).

This guide lists the rules generally applicable for EMC.

DECLARATION OF CE CONFORMITY

A declaration of CE conformity is available on request.

Validation by Competent Body

Eurotherm has validated the compliance of TE200A products with the European Low Voltage Directive and with EMC standards through product design and laboratory testing.

The tests carried out on TE200A products are listed in a Technical Construction File validated by the LCIE (Central Laboratory for the Electrical Industries), a Recognised Competent Body.

Further information

For any further information, or if in doubt, please contact Eurotherm Controls where qualified staff are available to advise or assist you with the commissioning of your installation.

PRECAUTIONS

Safety symbols

Important safety precautions and special information are indicated in the text of the manual by two symbols:



DANGER

This symbol means that failure to take note of the information given in this manual may have serious consequences for the safety of personnel and may even result in electrocution.



WARNING

This symbol means that failure to take note of the information may

- have serious consequences for the installation or
- lead to the incorrect operation of the power unit.

These symbols must be observed for particular points.
However the whole of the manual remains applicable.

Personnel

The installation, configuration, commissioning and maintenance of the power unit should only be carried out by personnel qualified and trained to work with low voltage electrical equipment in an industrial environment.

Independent alarm

Given the value of the equipment controlled by TE200A products it is the responsibility of the user, and it is highly recommended, that an independent safety device (alarm) should be installed. This alarm must be tested regularly.

Eurotherm can supply suitable equipment.

Chapter 1

IDENTIFYING THE TE200A POWER CONTROLLERS

	Page
GENERAL INTRODUCTION TO THE TE200A SERIES	1-2
TECHNICAL SPECIFICATION	1-5
PRODUCT CODE	1-7
EXAMPLE OF PRODUCT CODE	1-8
SERIAL NUMBER LABELS	1-8

Chapter 1 IDENTIFYING THE CONTROLLERS

GENERAL INTRODUCTION TO THE TE200A SERIES

The TE200A series of controllers are thyristor units designed to control the electrical power in industrial three-phase loads.

A TE200A series controller is made up of two channels, each comprising a pair of thyristors connected in anti-parallel, and a direct (unswitched) channel.

The TE200A series is designed to control three-phase resistive loads:

- elements with a low temperature coefficient
- short-wave infrared elements (except for the 63A model).

Three-phase loads can be connected:

- in star without neutral
- in closed delta

The wiring of the controller is independent of the supply phase rotation.

The nominal line-to-line voltage ranges; from 200Vac to 500Vac.

The nominal currents, defined at an ambient temperature of 45°C, of TE200A series controllers are between 16A and 63A, per phase.

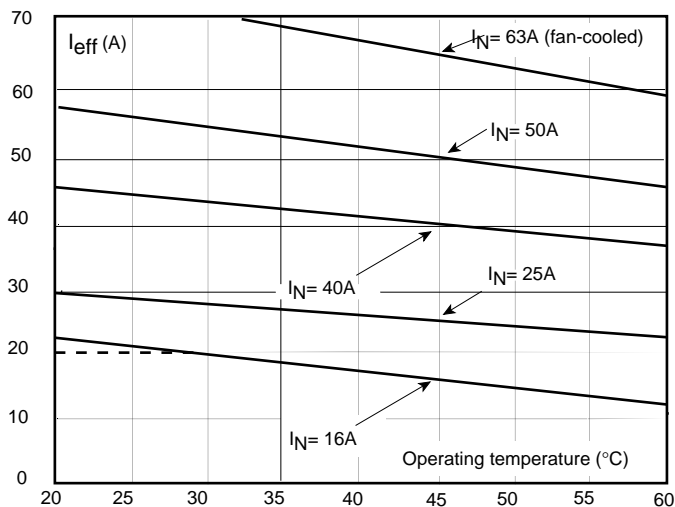

Figure 1-1 Current derating per phase as a function of ambient temperature (dotted line: current limited by recommended fuse)

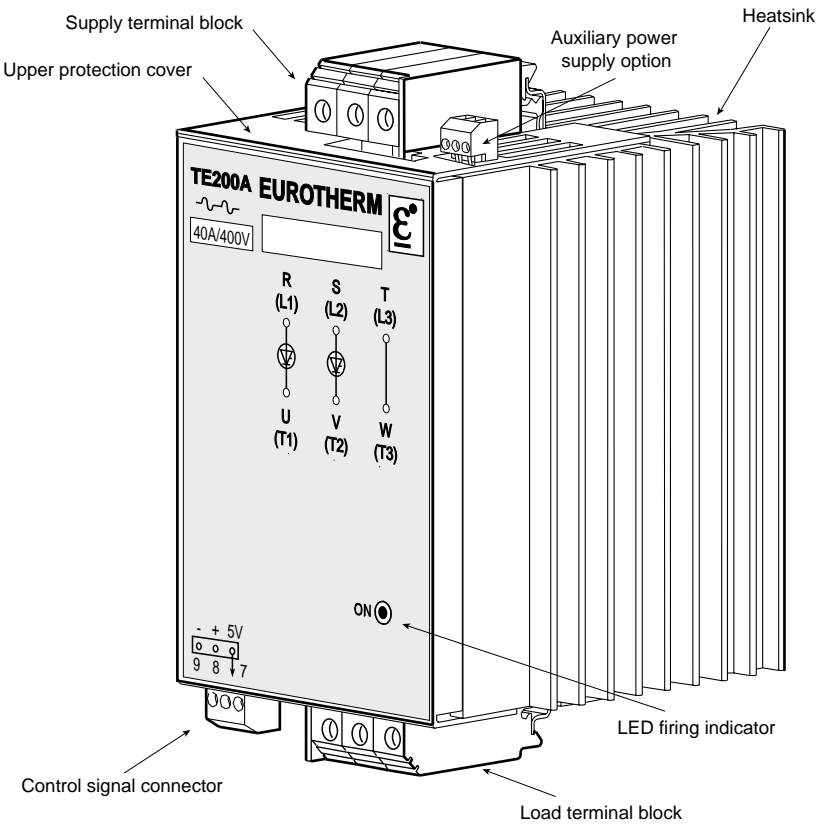

Figure 1-2 Overview of the TE200A series controller (non fan-cooled unit)

The unit is controlled by analogue signals.

The analogue input signals have two voltage ranges: 0 to 5V or 0 to 10V, and one current range: 4 to 20mA.

Local control is possible via a potentiometer (10k Ω).

The +5V user-voltage output is provided for this purpose.

The electronics of TE200A controllers are self-supplied from the power voltage and do not require external connections (unless specified otherwise).

The control function for TE200A includes line voltage squared (V^2) compensation for line variations in the range $\pm 10\%$ of the nominal voltage of the controller; stability is better than $\pm 2\%$.

TE200A series controllers have two thyristor firing modes:

- Burst-firing - the modulation cycle is from 30 cycles at 50% power (15 cycles ON, 15 cycles OFF) to a modulation time of approx 6 seconds at very low and very high power demands.
- Single-cycle (one cycle of firing and one cycle of non-firing at 50% power).

A TE200A controller is equipped with:

- A 'driver board' which implements the control function and EMC filtering, and provides power for the electronics. This board is also responsible for the input signal and operating mode configurations.
- A 'firing board' which triggers thyristor firing.

The filter which provides immunity against electromagnetic interference is located between the power phases.

The user terminal block below the controller is used for the input signal connection without needing access to the inside of the controller.

A green LED, labelled 'ON', indicates thyristor firing and is located on the front fascia.

TE200A power controllers are designed to be bulkhead or DIN rail mounted.

The 63A rated unit must be permanently fan-cooled.

The fan power supply is 115Vac or 230Vac (to be specified when ordering the controller).

TECHNICAL SPECIFICATION

The TE200A series of thyristor units is intended for two-phase control of an industrial three-phase load.

Power

Nominal current (per phase)	16A, 25A, 40A, 50A or 63A (at 45°C)
Line-to-line voltage	200Vac to 500Vac ($\pm 10\%$)
Operating voltage (calibration)	200V to 277V and 380V to 500V
Supply frequency	50Hz and 60Hz ($\pm 2\text{Hz}$) automatic selection
Dissipated power (thyristor unit)	1.3W (approx.) per amp, per phase
Dissipated power (external fuses)	0.7W (approx.) per amp per phase
Insulation (1 min test)	In series 2000Vac, 50Hz between power and earth and 3600Vac, 50Hz between power and control
Cooling	Natural convection for 16A to 50A ratings Permanent fan-cooling for 63A rating
Fan power supply (63A unit)	115Vac or 230Vac (selected in order code)
Load	Resistive three-phase load with a low temperature coefficient
	Short-wave infrared elements (except for 63A rating)
Supply phases	Wiring independent of the phase rotation
Load configuration	3-wire: Closed delta or star without neutral
Fuses	External (order separately) - see chapter 7

CE Marking

Electrical safety	TE200A controllers carry the CE mark in compliance with the essential requirements of the European Low Voltage Directive 73/23/EC (amended by the Directive 93/68/EC)
-------------------	---

Electromagnetic compatibility

Immunity and Emissions	TE200A products comply with Electromagnetic Compatibility test standards (see page iv).
------------------------	---

Control

External control signal	Analogue Voltage: 0 to 5V or 0 to 10V. Current 4 to 20mA
Input impedance (approx.)	Voltage input: 100k Ω , current input: 250 Ω
Configuration	'Coffee beans' on driver board
Local control	10kW potentiometer supplied by +5V user-voltage (input configured as 0 to 5V)

Thyristor firing

Firing modes	Burst-firing: Number of firing and non-firing cycles at 50% power: 15 ± 2 Single-cycle: One firing cycle and one non-firing cycle at 50% power
Switching	Conduction starts and ends at zero voltage
Indication	Thyristor firing is signalled by a green LED

Control performance

Control type	The total power controlled in the three-phase load (supply voltage squared) is proportional to the setpoint
Linearity	Better than $\pm 2\%$ of full scale
Stability	With $\pm 10\%$ variations of the supply voltage, stability is better than $\pm 2\%$ of full scale

Option

Auxiliary power supply	It is possible to operate on non-standard three-phase supply by separately supplying the electronics with 115Vac or 230Vac
------------------------	--

Environment

Operating temperature	0°C to +60°C at maximum altitude of 2000m (see derating curves)
Storage temperature	-10°C to +70°C
Thyristor protection	High-speed external fuses - ordered separately (see chapter 7) (except for short-wave infrared application) Internal MOVs (varistors) and RC snubbers
Protection	IP20 (in compliance with Standard IEC 529)
External wiring	To be carried out in compliance with Standard IEC 364
Operating atmosphere	Non-explosive, non-corrosive, non-conductive
Humidity	RH: 5% to 95%, non-condensing, non-streaming
Pollution	Pollution degree 2 permissible, defined by IEC 664 Over-voltage category III, defined by IEC 664

In order to maintain its 'leading edge', Eurotherm may have to make changes to its specifications without advance notice.

For any further information, or if in doubt, please contact Eurotherm Controls.

PRODUCT CODE

TE200A/Current/Voltage/Cooling/Signal/Firing/Mounting/Language/Option/00

Nominal current	Code
16 amps	16A
25 amps	25A
40 amps	40A
50 amps	50A
63 amps (fan cooled)	63A

Mains voltage* (line-to-line)	Code
200 volts	200V
230 volts	230V
240 volts	240V
277 volts	277V
380 volts	380V
400 volts	400V
415 volts	415V
440 volts	440V
480 volts	480V
500 volts	500V

Fan supply	Code
Without fan-cooling (16A to 50A)	000
With fan-cooling (63A):	
115Vac	115V
230Vac	230V

Input signal	Code
0 to 5 volts	0V5
0 to 10 volts	0V10
4 to 20 milliamps	4mA20

Thyristor firing mode	Code
Burst-firing	FC
Single-cycle	FC1

Mounting	Code
Bulkhead	BKD
DIN rail	DIN

Manual language	Code
French	FRA
English	ENG
German	GER
Italian	ITA

Option*	Code
Power supply separate from electronics (non-standard power supply)	115V 230V

*

Non-standard mains: use the coding for the voltage immediately above and choose option of power supply separate from electronics.

EXAMPLE OF PRODUCT CODE

Controller and installation parameters

Nominal load current	35 amps
Nominal supply voltage	415 volts line-to-line
Input signal	0 to 5 volts
Firing mode	Single-cycle
Mounting	On DIN rails
User manual	In English

Controller code:

TE200A / 40A / 415V / 000 / 0V5 / FC1 / DIN / ENG / 00

SERIAL NUMBER LABELS

Two identification labels provide all the information relating to the factory settings of the controller.

The identification labels are located on the sides of the unit.

EUROTHERM	2.20
WORTHING, ENGLAND : 1903 268500	
MODEL : TE200A/40A/415V/000/0V5/FC1/DIN/ENG/00	
SERIAL No. : INT100/002/001/10/97	0F222935

CURRENT : 40A	VOLTAGE : 415V	AUX. POWER SUPPLY : SELF-SUPPLIED
INPUT : 0-5V		FAN POWER SUPPLY : NONE
FIRING : SINGLE-CYCLE		
FUSE : FERRAZ B093910. ANY NON-SPECIFIED FUSE INVALIDATES GUARANTEE		

Figure 1-3 Example of identification labels for a TE200A controller
The information corresponds to the product code example

Warning!

Following any re-configuration on the part of the user, there is no guarantee that the controller will correspond to the label information

Chapter 2

INSTALLATION

	Page
INSTALLATION - SAFETY	2-2
DIMENSIONAL DETAILS	2-3
Non fan-cooled controllers	2-3
Fan-cooled controllers	2-4
MOUNTING DETAILS	2-5
DIN rail mounting	2-5
Bulkhead mounting	2-6

Chapter 2 INSTALLATION

Please read thoroughly before installing the controller

INSTALLATION - SAFETY



Danger !

TE200A units must be installed by personnel qualified and trained to work with low voltage electrical equipment in an industrial environment.

Units must be installed in electrical cabinets correctly fan-cooled to ensure that condensation and pollution are excluded.

The cabinet must be closed and bonded to the safety earth in accordance with Standards NFC 15-100, IEC 364 or current national Standards.

For installations which are fan-cooled, it is recommended that a fan-failure detection device or a thermal safety cut-out should be fitted in the cabinet.

TE200A units may be bulkhead or DIN rail mounted.

The units must be mounted with the heatsink positioned vertically, with no obstructions above or below which could inhibit or impede airflow.

If several units are mounted in the same cabinet, they should be arranged in such a way that air expelled from one cannot be drawn into the unit located above it.

Warning !



The units are designed to be used at an ambient temperature less than or equal to 45°C at full load or up to 60°C at partial load (see Current derating curves, page 1-2).

Leave a minimum gap of 5cm between two units placed side by side.

Excessive overheating of the controller may lead to incorrect operation of the unit. This may in turn cause damage to the components.

DIMENSIONAL DETAILS

Non fan-cooled controllers

The overall dimensions of non fan-cooled TE200A controllers (16A to 50A ratings) are given in Figure 2-1. Weight of non fan-cooled TE200A controller: 2.3kg

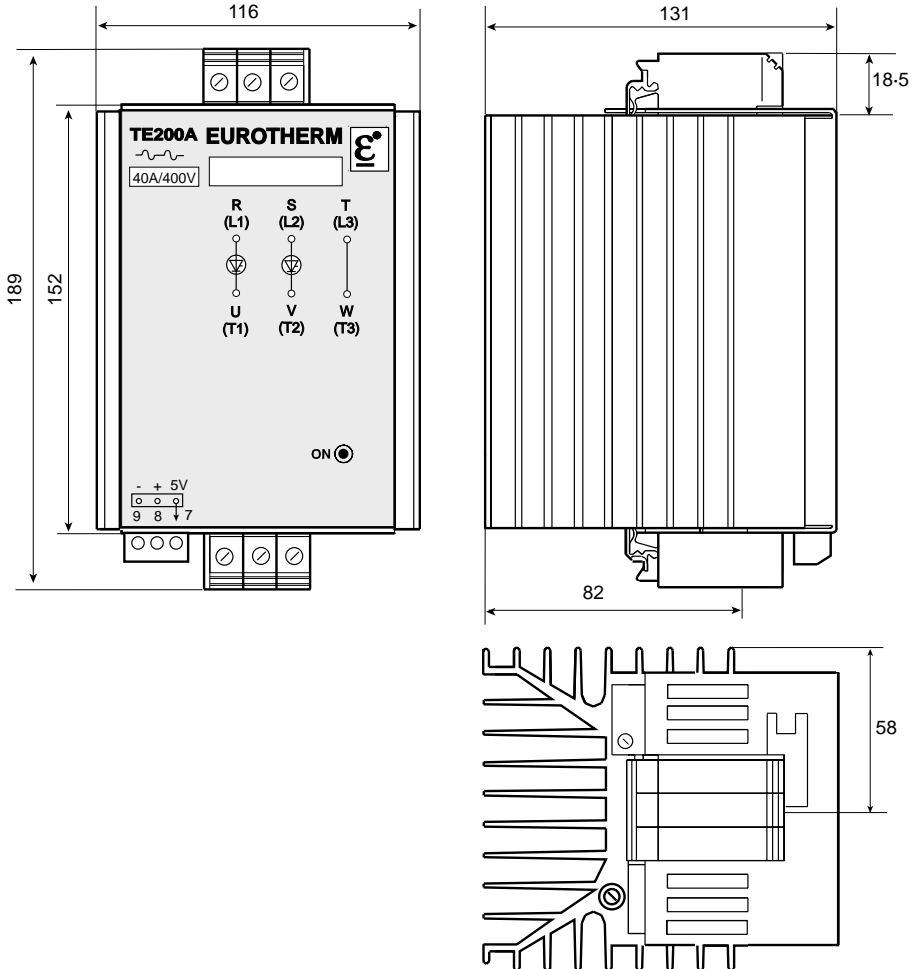

Figure 2-1 Dimensions (mm) of non fan-cooled TE200A controller

Fan-cooled controllers

63A rating TE200A controllers have permanent fan-cooling.

Weight of fan-cooled TE200A controller: 2.9kg

The overall dimensions of the fan-cooled TE200A controller are given in Figure 2-2.

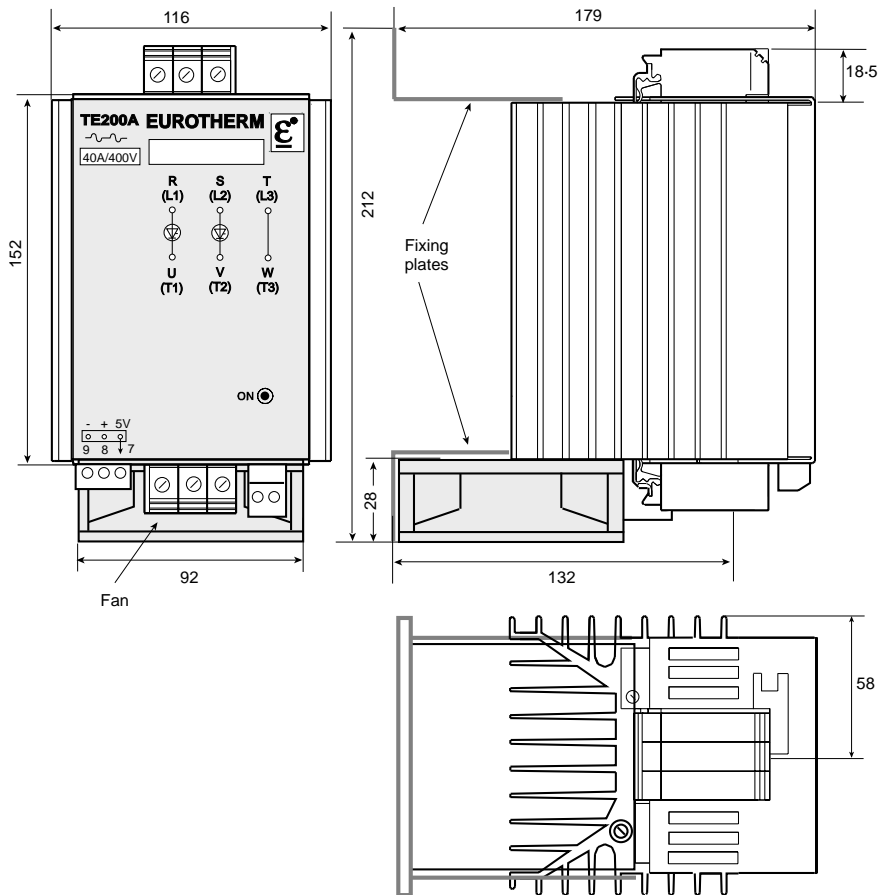

Figure 2-2 Dimensions (mm) of fan-cooled TE200A controller (63A rating)

MOUNTING DETAILS

TE200A controllers may be mounted:

- On two DIN rails (code DIN)
- On a bulkhead (code BKD)

DIN rail mounting

For mounting TE200A controllers, use symmetrical DIN rails to comply with Standard EN 50022.

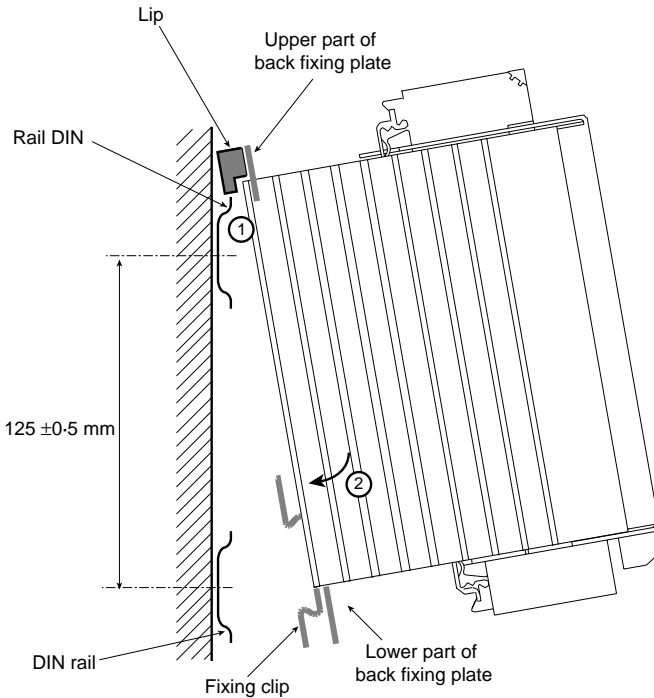

Figure 2-3 DIN rail mounting for TE200A controller

To mount the TE200A controller on DIN rails:

1. Offer up the unit by first engaging the two lips on the upper part of the fixing plate (back plate of controller) on to the upper DIN rail.
2. Clip the controller (by its spring clip) on to the lower DIN rail, making sure that the clip is properly engaged.

Bulkhead mounting

Two fixing plates, supplied with the controller (code BKD), are used for bulkhead mounting. For this type of mounting, use the following instructions:

- Drill three holes for M6 screws following the dimensions given in Figure 2-4
- Fix the upper plate on to the panel using the oblong hole at the top of the controller
- Install the lower plate with two M6 screws
- Insert the fixing lugs of the controller into the lower plate
- Slightly undo the central screw holding the upper fixing plate in order to slide it upwards, position the controller on the lower fixing plate and slide the upper plate back down on to the slots on the heatsink.

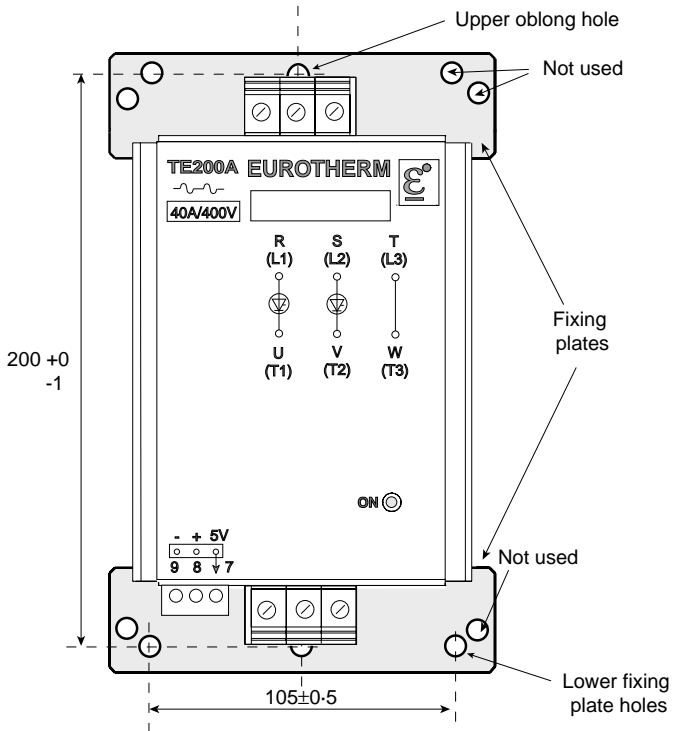

Figure 2-4 Bulkhead drilling and mounting dimensions (in mm) for the TE200A controller

Chapter 3

WIRING

	Page
WIRING - SAFETY	3-2
POWER WIRING	3-3
Connections	3-3
Power wiring diagram	3-4
USER TERMINAL BLOCKS	3-5
General introduction	3-5
External input wiring	3-6
Control wiring in local mode	3-7
Power supply separate from electronics (option)	3-8

Chapter 3 WIRING

WIRING - SAFETY

TE200A series units have an IP20 protective cover.



Danger !

Wiring must only be carried out by personnel who are qualified to work in a low voltage industrial environment.

It is the user's responsibility to wire and protect the installation in accordance with current professional Standards. A suitable device ensuring electrical isolation between the equipment and the supply must be installed upstream of the unit in order to permit safe operation.



Danger !

Before any connection or disconnection, ensure that power and control cables or leads are isolated from voltage sources.

For safety reasons, the safety earthing cable must be connected before any other connection is made during wiring and it should be the last cable to be disconnected. The safety earth is connected to the screw located on the upper part of the controller and is denoted by the symbol:



Warning !

To ensure correct grounding (EMC) of the TE200A unit, make sure that it is correctly mounted on the reference ground surface (panel or bulkhead).

Failing this, it is necessary to add a ground connection at most 10cms long between the earth connection and the reference ground surface.



Danger !

This connection, which is intended to ensure good ground continuity, can never be used to replace the safety earth connection.

POWER WIRING

Connections

The power terminal blocks (mains and load) are cage terminal blocks.

The control terminal block has a plug-in screw connector.

The safety earth is connected to an M5 screw.

The terminal capacities and tightening torques are given in Table 3-1.

Parameter	Power & load supply	Safety earth	Control
Terminal capacity (mm ²)	10 to 25	Equal to or greater than power cross-section	1.5
Tightening torque (Nm)	2	2	0.7

Table 3-1 TE200A connection details



Warning !

The cross-section of the conductors to be used must comply with Standard IEC 943.

Power wiring diagram

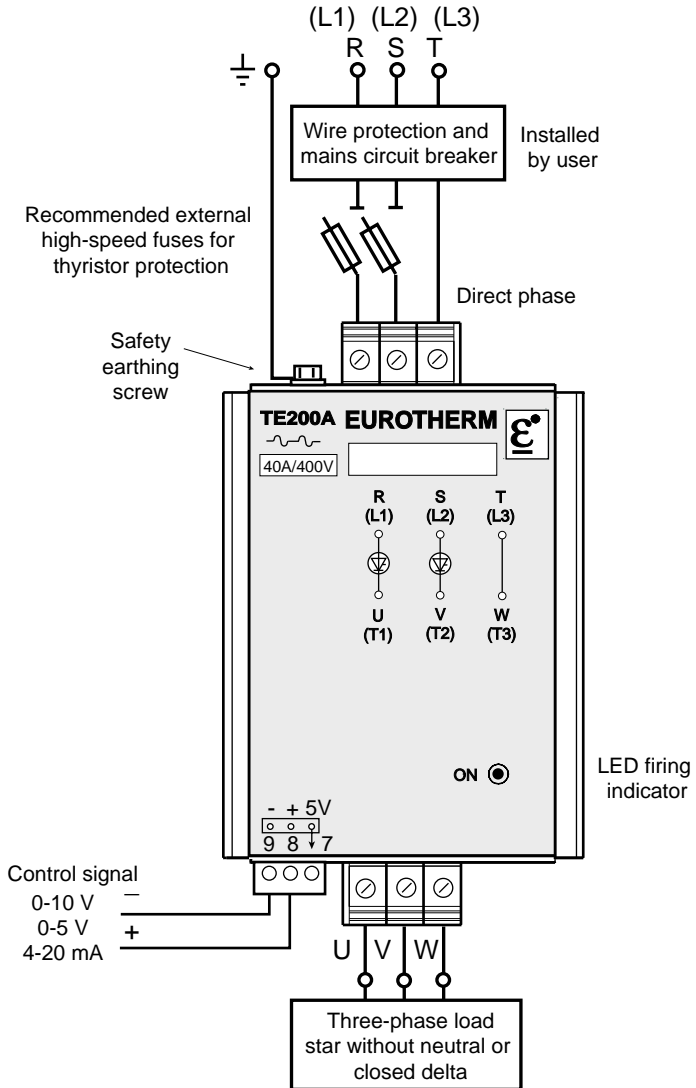

Figure 3-1 Power and safety earth wiring for a load connected in 'star without neutral' or in 'closed delta' (3-wire configuration)

USER TERMINAL BLOCKS

General introduction

The user terminal blocks comprise:

- A control terminal block
- A fan terminal block (for the 63A rating)
- An auxiliary power supply terminal block (option).

The connectors plug in.

The control terminal block is located below the controller on the left side.

The fan terminal block is located below the controller on the right side.

The auxiliary power supply terminal block is located above the controller on the right side (option).

Terminal numbers	Function
7	User output +5V (for wiring manual control potentiometer)
8	Control input (signal +ve)
9	Control 0V
10 & 12	Power supply separate from electronics (option)
11	Not used
115V or 230V	Fan supply (63A rating)

Table 3-2 Function of user terminals



Warning !

Both the fan connection (for the 63A rating) and the separate electronics supply ('auxiliary power supply' option) must have 0.5A protective fuses installed in each feed wire connected to a supply phase.

External input wiring

The external analogue control signal must be connected to the control connector between terminal 8 ('+ Input') and terminal 9 ('0V').

The input is configured at the factory by means of the 'coffee beans' on the driver board.

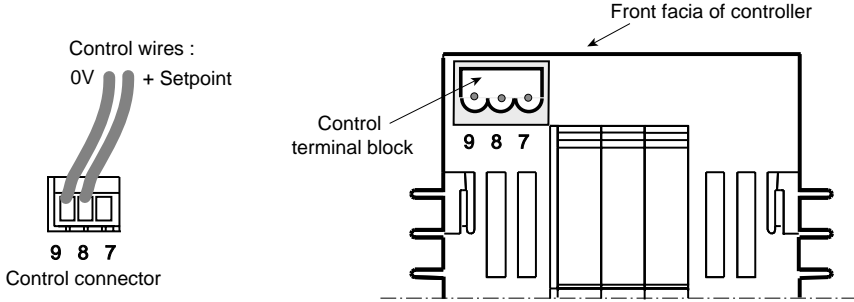

Figure 3-2 Control terminal block (view from below)

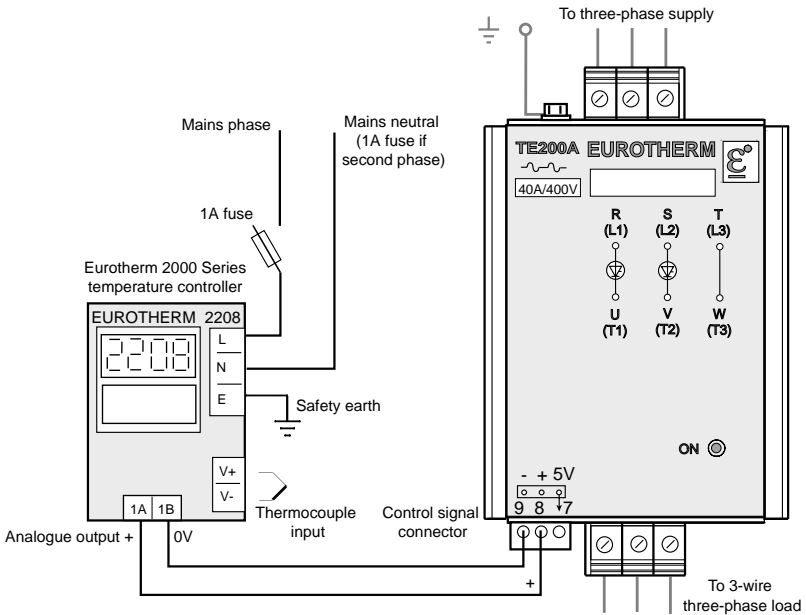

Figure 3-3 External control signal wiring

Control wiring in local mode

The controller can be driven in local mode by a potentiometer.

For operation with manual control, a 10kΩ external potentiometer must be used, connected between terminals 9 ('0V') and 7 ('+5V').

The potentiometer wiper is connected to the control terminal block input (terminal 8).

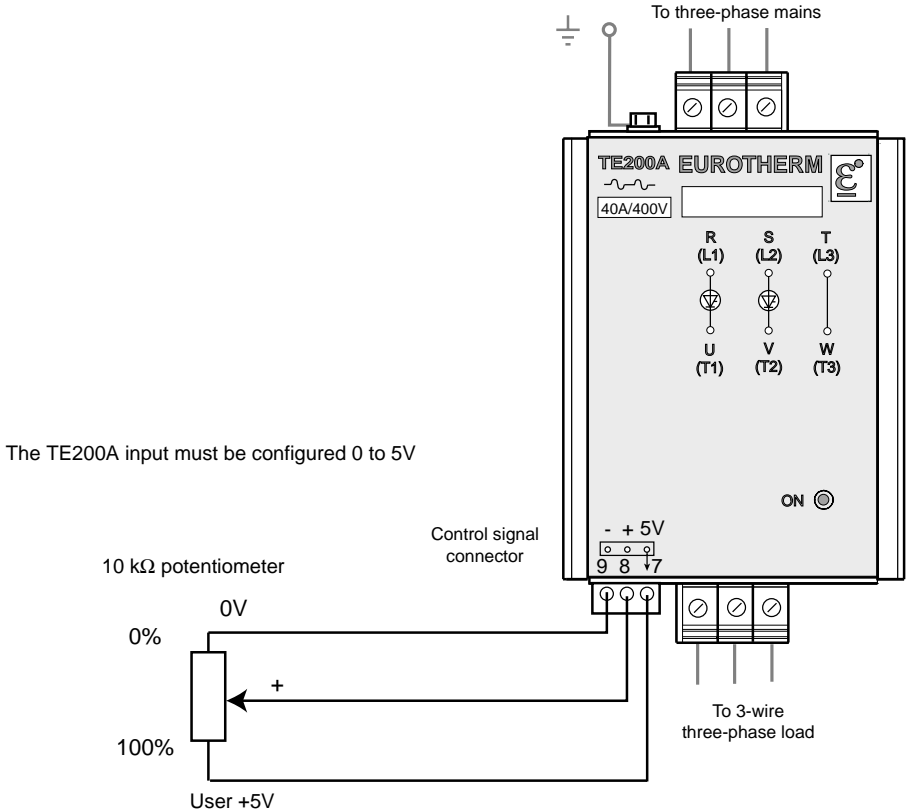

Figure 3-4 Manual control wiring using an external potentiometer

Power supply separate from electronics (option)

TE200A controllers can be used with non-standard mains. If a TE200A series controller is used with a mains supply, the voltage of which is not shown in the voltage codes, the control electronics must be fed separately from the power by a 115Vac or 230Vac auxiliary supply.

The separate power supply must be connected between terminals 10 and 12 (terminal 11 is not used).

The auxiliary power supply must be in phase or anti-phase with the power voltage between the controlled phases of the unit (phases R and S).

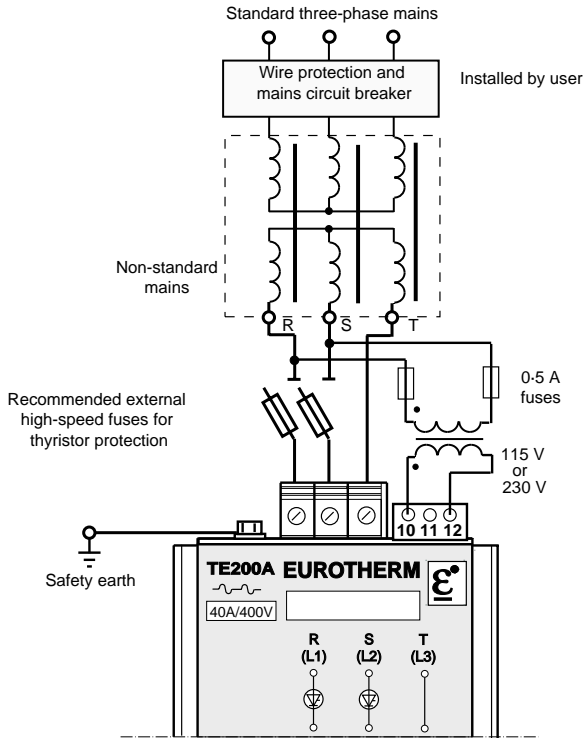

Figure 3-5 Connection of auxiliary power supply (option)



Warning !

Each auxiliary power supply feed wire connected to a supply phase must be protected by a 0.5A fuse.

Chapter 4

CONFIGURATION

	Page
CONFIGURATION - SAFETY	4-2
DRIVER BOARD CONFIGURATION	4-3
General introduction	4-3
Location of 'coffee beans'	4-3
Control signal configuration	4-4
Thyristor firing mode configuration	4-4

Chapter 4 CONFIGURATION

CONFIGURATION - SAFETY

The controller is configured at the factory by soldered 'Coffee beans', located on the driver board.



Important!

The controller is supplied fully configured in accordance with the product code on the identification label and is ready for operation after wiring.

This chapter is included with a view to:

- Checking that the configuration is suitable for the application
- Modifying, if necessary, certain characteristics of the controller on site.



Danger!

For safety reasons, re-configuration of the controller using the 'coffee beans' must be carried out with the unit switched off and by personnel qualified and trained to work with electrical equipment in a low voltage industrial environment.

Before starting the re-configuration procedure, ensure that the controller is isolated and that any accidental power-up is not possible.

Check that there are no extraneous objects left in the unit, and in particular, no solder residue.

After re-configuring the controller, amend the codes on the identification label to prevent any subsequent maintenance problems.

DRIVER BOARD CONFIGURATION

General introduction

The 'coffee beans' located on the driver board are used to configure:

- The type and level of the control signal
- The thyristor firing mode.

Location of 'Coffee beans'

The 'coffee beans' GR are shown only by their number on the driver board.

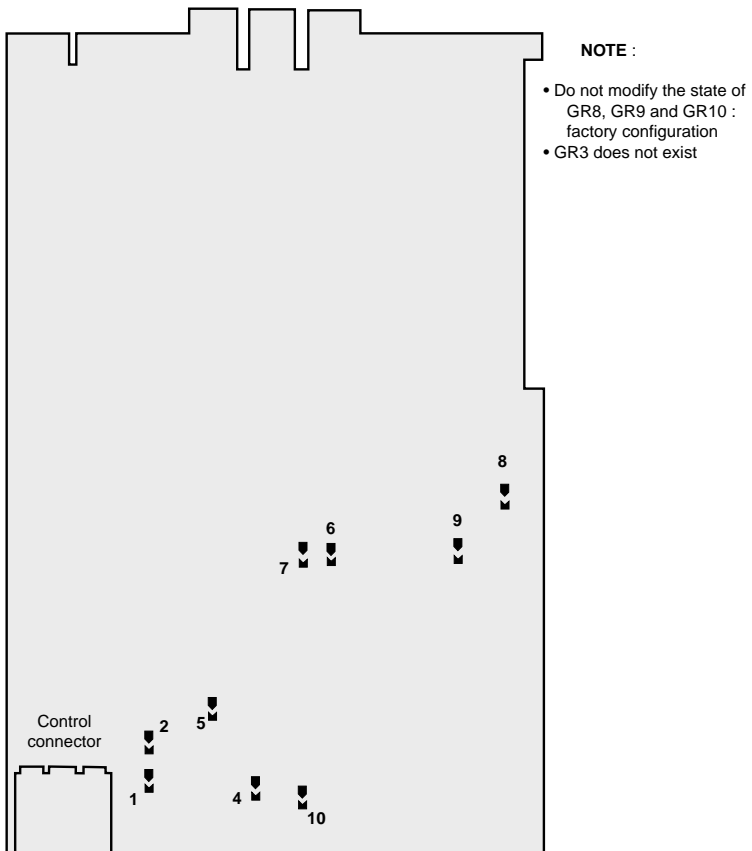

Figure 4-1 Location of configuration 'coffee beans' (GR) on the driver board (solder-side view)

**Attention!!**

In the 'coffee bean' configuration tables shown below:

- X : denotes the solder link
 - : denotes absence of solder link. (open)

Control signal configuration

The three 'coffee beans' GR1, GR2 and GR5 are used to configure the controller input.

Type and range of control signal		'Coffee beans'		
		GR1	GR2	GR5
Voltage	0 to 5V	-	X	-
	0 to 10V	-	-	-
Current	4 to 20mA	X	X	X
Local control	10k Ω potentiometer	-	X	-

Table 4-1 Input configuration

Thyristor firing mode configuration

The firing mode is configured by 'coffee beans' GR4, GR6, GR7.

Thyristor firing mode	'Coffee beans'		
	GR4	GR6	GR7
Burst firing	X	-	X
Single-cycle	-	X	-

Table 4-2 Thyristor firing mode configuration

Chapter 5

OPERATION

	Page
THYRISTOR FIRING MODES	5-2
General introduction	5-2
‘Burst-firing’ mode	5-3
‘Single-cycle’ mode (‘1-cycle burst-firing’)	5-5
CONTROL OPERATION	5-6

Chapter 5 OPERATION

THYRISTOR FIRING MODES

General introduction

TE200A controllers have two thyristor firing modes:

- Burst-firing (FC)
- Single-cycle (FC1)

The configuration of one of these modes is performed in the factory by soldering the 'coffee beans' as described in the chapter on configuration.

The user has the option of re-configuring the thyristor firing mode (refer to Table 4-2).

'Burst-firing' mode

Burst-firing mode is a duty cycle mode which consists of supplying a series of complete mains voltage cycles to the load.

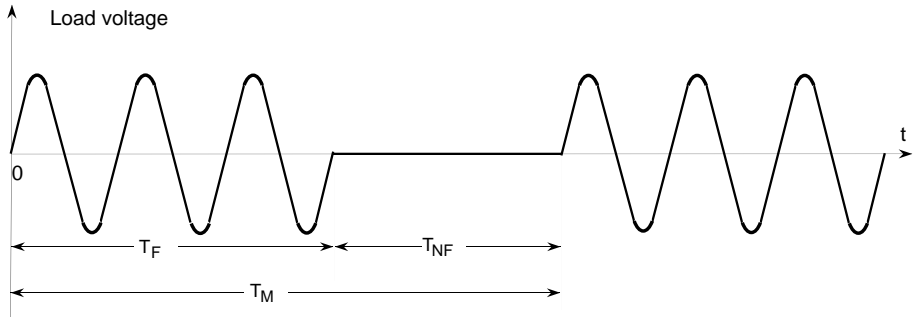

Figure 5-1 'Burst-firing' mode
(T_F - firing time; T_{NF} - non-firing time; T_M - modulation time)

Thyristor firing and non-firing are synchronised with the mains and, for a resistive load, are performed at zero voltage for each load.

This type of firing eliminates steep rates of voltage applied to the load, minimises interference to the supply network and, above all, avoids generating radio frequency interference (RFI).

In 'Burst-firing' mode, the power delivered to the load depends on the firing time T_F and the non-firing time T_{NF} .

The load power is proportional to the firing rate (τ) which is defined by the ratio of the firing time T_F to the modulation time $T_M = T_F + T_{NF}$

The firing rate or duty cycle is expressed by the following ratio:

$$\tau = \frac{T_F}{T_F + T_{NF}}$$

The load power can be expressed by:

$$P = \tau \cdot P_{MAX}$$

where P_{MAX} represents the load power for full thyristor firing.

The modulation time in 'Burst-firing' mode is variable according to the power demand.

For example, at 50% power, the typical value of the modulation time is:

0.6s (at 50Hz):
 15 ± 2 firing cycles and
 15 ± 2 non-firing cycles.

The control system adjusts the basic 'Burst-firing' modulation time in order to retain optimum accuracy irrespective of the power demand.

As a result of this type of modulation, TE200A offers precision control which adapts to each particular setpoint.

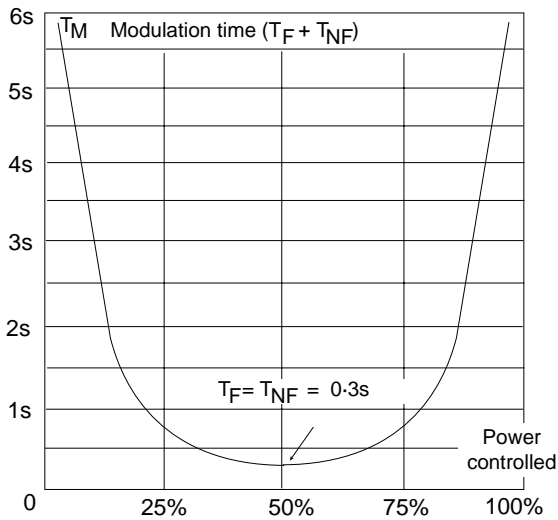

Figure 5-2 Modulation time as a function of power in 'Burst-firing' mode

'Single-cycle' mode ('1-cycle Burst-firing')

This 'Burst-firing' mode has a single firing cycle or a single non-firing cycle and is called 'Single-cycle'.

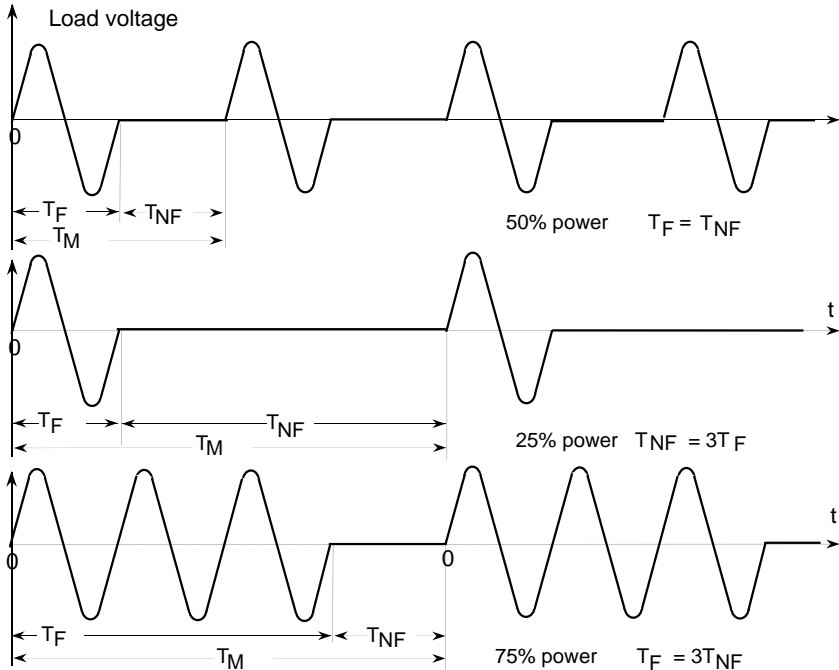

Figure 5-3 'Single-cycle' firing mode

At 50% power, the modulation time in 'Single-cycle' mode is 40ms:

- 1 firing cycle (20ms at 50Hz)
- 1 non-firing cycle (20ms at 50Hz)

For a setpoint less than 50%:

- The firing time remains constant (1 cycle)
- The non-firing time increases and, as a consequence,
- The modulation time increases

For a setpoint greater than 50%:

- The non-firing time remains constant (1 cycle)
- The firing time and the modulation time increase.

CONTROL OPERATION

TE200A controllers include an internal control loop.

The control algorithm of the TE200A series takes into account the value of the r.m.s. load voltage squared. The square of the r.m.s. load voltage represents the power dissipated in a purely resistive load whose value is constant with temperature.

The total output power of the controller is linear between 0% and 100% of maximum power for an analogue input signal varying between 4% and 96% of full scale.

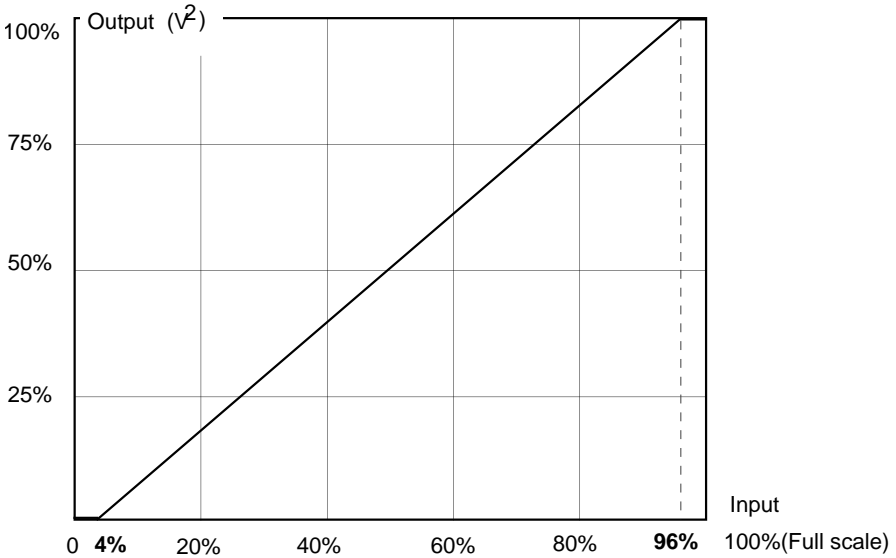

Figure 5-4 'Input/Output' response curve

Control precision is guaranteed to $\pm 2\%$ of the total maximum power dissipated in the load (for constant resistance).

The output power of the controller is calibrated according to the nominal voltage specified when ordering.

Chapter 6

COMMISSIONING PROCEDURE

	Page
COMMISSIONING PROCEDURE - SAFETY	6-2
CHECKING THE CHARACTERISTICS	6-3
Load current	6-3
Supply voltage	6-3
Auxiliary power supply voltage (option)	6-3
Control signals	6-3
POWERING UP THE CONTROLLER	6-4

Chapter 6 COMMISSIONING PROCEDURE

Read this chapter carefully before commissioning the controller

COMMISSIONING PROCEDURE - SAFETY



Important!

Eurotherm cannot be held responsible for any damage to persons or property or any financial loss or costs arising from incorrect use of the product or failure to observe the instructions contained in this manual.

It is therefore the user's responsibility to ensure, before commissioning the unit, that all the nominal ratings of the power unit are compatible with the conditions of use and the installation.



Danger!

A thyristor is not an isolating device.
Touching a load terminal even with a zero load current is as dangerous as touching mains live.

Only personnel qualified and trained to work with low voltage electrical equipment in an industrial environment should have access to the interior of the unit.

Access to internal components of the controller is prohibited to users who are not authorised to work in an industrial low voltage electrical environment.

The temperature of the heatsink may exceed 100°C.
Avoid all contact, even occasional, with the heatsink when the controller is operational. The heatsink remains hot for around 15mins after the unit has been switched off.

CHECKING THE CHARACTERISTICS

Load current

The maximum load current must be less than or equal to the value of the nominal current of the unit, taking into account the load and power supply variations.

For the total power (P) of a three-phase load and for the line-to-line voltage V_L , the current is:

$$I = \frac{P}{\sqrt{3} \times V_L}$$

If three identical loads are configured in closed delta, the current of each phase of the power controller is $\sqrt{3}$ times greater than the current in each branch of the load.

Supply voltage

The nominal value of the TE200A voltage must be greater than or equal to the line-to-line voltage of the supply used.



Warning!

In order for the control algorithm to function correctly, the nominal unit voltage rating must be as close as possible to the supply voltage.

Auxiliary power supply voltage (option)

In the case of operation with non-standard three-phase mains, a separate power supply for the electronics must be provided at either 115Vac or 230Vac.

The auxiliary power supply voltage is set at the factory from the ordered product code.

Control signals

Configuration of the 'coffee beans' on the driver board must be compatible with the type and level of the control signals (see chapter 4).

POWERING UP THE CONTROLLER

TE200A series controllers are ready to operate correctly immediately after installation and wiring in accordance with this user manual.

After checking that the nominal parameters of the controller (voltage, current, input signal) are compatible with those of the installation, apply volts to the controller.

Check that the current in each phase of the controller is equal to 0 in the absence of the control signal.

Make sure that the r.m.s. current in each phase does not exceed the nominal rating when the setpoint is at maximum.

Chapter 7

MAINTENANCE

	Page
FUSES	7-2
Thyristor protection	7-2
Protection of auxiliary voltage connection	7-4
SERVICING	7-5
TOOLS	7-5

Chapter 7 MAINTENANCE



Danger!

The controller must be maintained by personnel qualified and trained to work with low voltage electrical equipment in an industrial environment.

The user's installation must be protected upstream (non high-speed fuses, thermal or electromagnetic circuit breaker, suitable fuse-isolator) and must comply with current standards.

FUSES

Thyristor protection

Thyristors in the TE200A series controllers are protected in the following way:

- by external high speed fuses against overcurrents (except for short-wave infrared applications); these fuses must be ordered separately;
- by RC snubbers and internal MOVs (varistors) which protect against over-fast voltage variations and transient overvoltages when the thyristors are not conducting.



Danger!

High-speed fuses are used only for the internal protection of thyristors against large amplitude overloads.

Under no circumstances should these fuses be used to protect the installation.



Warning!

For the use of high-speed fuses in short-wave infrared applications, please contact Eurotherm Controls.



Warning!

For resistive loads (except short-wave infrared applications) the use of any fuses other than those recommended for thyristor protection will invalidate the guarantee.

To protect the thyristors in the TE200A, depending on the wiring, the following combinations may be used:

- Two 'single-phase fuse and fuseholder' assemblies installed in the controlled phases or
- One 'three-phase fuse and fuseholder assembly' installed between the TE200A controller and the line protection and mains circuit breaker, in this instance it is possible to install a solid link in the direct phase instead of a fuse,.

References for the 'fuse and fuseholder' assemblies and for spare fuses, are given in the following tables.

Nominal current		Spare fuse references:		Single phase fuse & fuseholder	Dimensions (mm)
TE200A	Fuse	Eurotherm	Ferraz	Code:	
16A	20A	CH260024	K330013	FU1038/16A/00	81 x 17.5 x 68
25A	30A	CH260034	M330015	FU1038/25A/00	81 x 17.5 x 68
40A	50A	CH330054	B093910	FU1451/40A/00	95 x 26 x 86
50A	63A	CS173087U063	T094823	FU2258/50A/00	140 x 35 x 90
63A	80A	CS173246U080	W076310	FU2760/63A/00	150 x 38 x 107

Table 7-1 Recommended high-speed fuses for thyristor protection
Single-phase fuseholders.

Nominal current		Spare fuse references:		Three phase fuse & fuseholder	Dimensions (mm)
TE200A	Fuse	Eurotherm	Ferraz	Code:	
16A	20A	CH260024	K330013	FU3038/16A/00	81 x 52.5 x 68
25A	30A	CH260034	M330015	FU3038/25A/00	81 x 52.5 x 68
40A	50A	CH330054	B093910	FU3451/40A/00	95 x 79 x 86
50A	63A	CS173087U063	T094823	FU3258/50A/00	140 x 108 x 90
63A	80A	CS173246U080	W076310	FU3760/63A/00	150 x 114 x 107

Table 7-2 Recommended high-speed fuses for thyristor protection
Three-phase fuseholders.

Maximum operating voltage for fuses: 500Vac (line-to-line).

Protection of auxiliary voltage connection

Protection fuses for both the fan connection (63A nominal current unit) and separate electronics supply ('Auxiliary power supply' option) must be installed in each conductor connected to a supply phase.

Auxiliary voltage (max)	0.5A fuse 6.3 x 32mm	Fuse-holder isolator	'Fuse-isolator' assembly dimensions (mm)
250V	CS174290U0A5	CP174292	63 x 15 x 52

Table 7-3 Recommended protective fuse for auxiliary voltage connection

SERVICING

TE200A controllers must be mounted with the heatsink positioned vertically, with no obstructions above or below which could inhibit or impede airflow.



Warning!

If several units are mounted in the same cabinet, they should be arranged in such a way that air expelled from one cannot be drawn into the unit located above it.

In order to ensure correct cooling of the unit, users are advised, depending on the degree of environmental pollution, to regularly clean the heatsink and (for 63A rating units) the protective fan guard.



Danger!

Cleaning should only be carried out when the supply is disconnected and at least 15 minutes after it has ceased operating.

Every six months check that the screws of the power and safety earth cables are correctly tightened (see 'Wiring' page 3-3).

TOOLS

Operation	Flat-blade screwdriver (mm)	Hex key
Safety earth wiring		HEX 8 (M5)
Power wiring	0.5 x 4	
Control, fan (63A rating) and auxiliary power supply (option) wiring	0.5 x 2.5	

Table 7-4 Tools

EUROTHERM CONTROLS LIMITED

UK SALES OFFICE

Eurotherm Controls Limited

Faraday Close, Durrington

Worthing

West Sussex BN13 3PL

TelephoneSales: (01903) 695888

Technical: (01903) 695777

Service: (01903) 695444

Fax (01903) 695666

Sales and support in over 30 countries worldwide

For countries not listed overleaf enquiries/orders to:

Eurotherm Controls Limited

Export Dept.,

Faraday Close, Durrington, Worthing

West Sussex, BN13 3PL

Telephone (01903) 268500

Fax (01903) 265982

Telex 87114 EUROWG G

