

Single-phase, 230 VAC (for Analog/pulse servo drives)

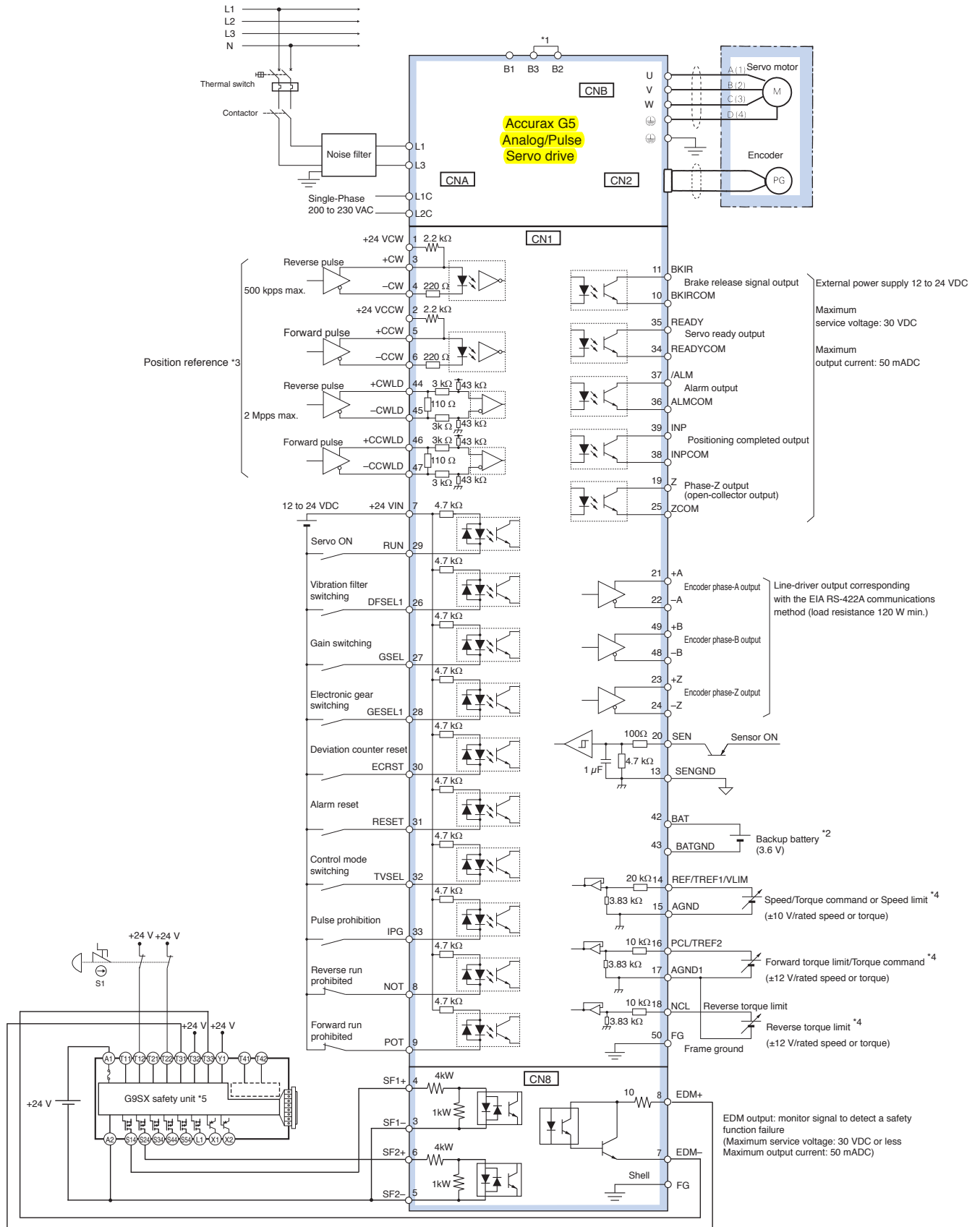

\*1 For servo drives from 750 W, B2 and B3 are short-circuited. If the internal regenerative resistor is insufficient, remove the wire between B2 and B3 and connect an external regenerative resistor between B1 and B2.  
 \*2 For use only with an absolute encoder. If a backup battery is connected to CN1 I/O connector, an encoder cable with a battery is not required.  
 \*3 Only available in Position control mode.  
 \*4 The input function depends on control mode used (Position, speed or torque control).  
 \*5 Wiring diagram example using the G9SX safety unit. If a safety unit is not used, keep the factory safety bypass connector installed in the CN8.

**Note:** The input function of pins 8,9 and 26 to 33, and output function of pins 10, 11, 34, 35, 38 and 39, can be changed via parameter settings.

Three-phase, 400 VAC (for Analog/pulse servo drives)

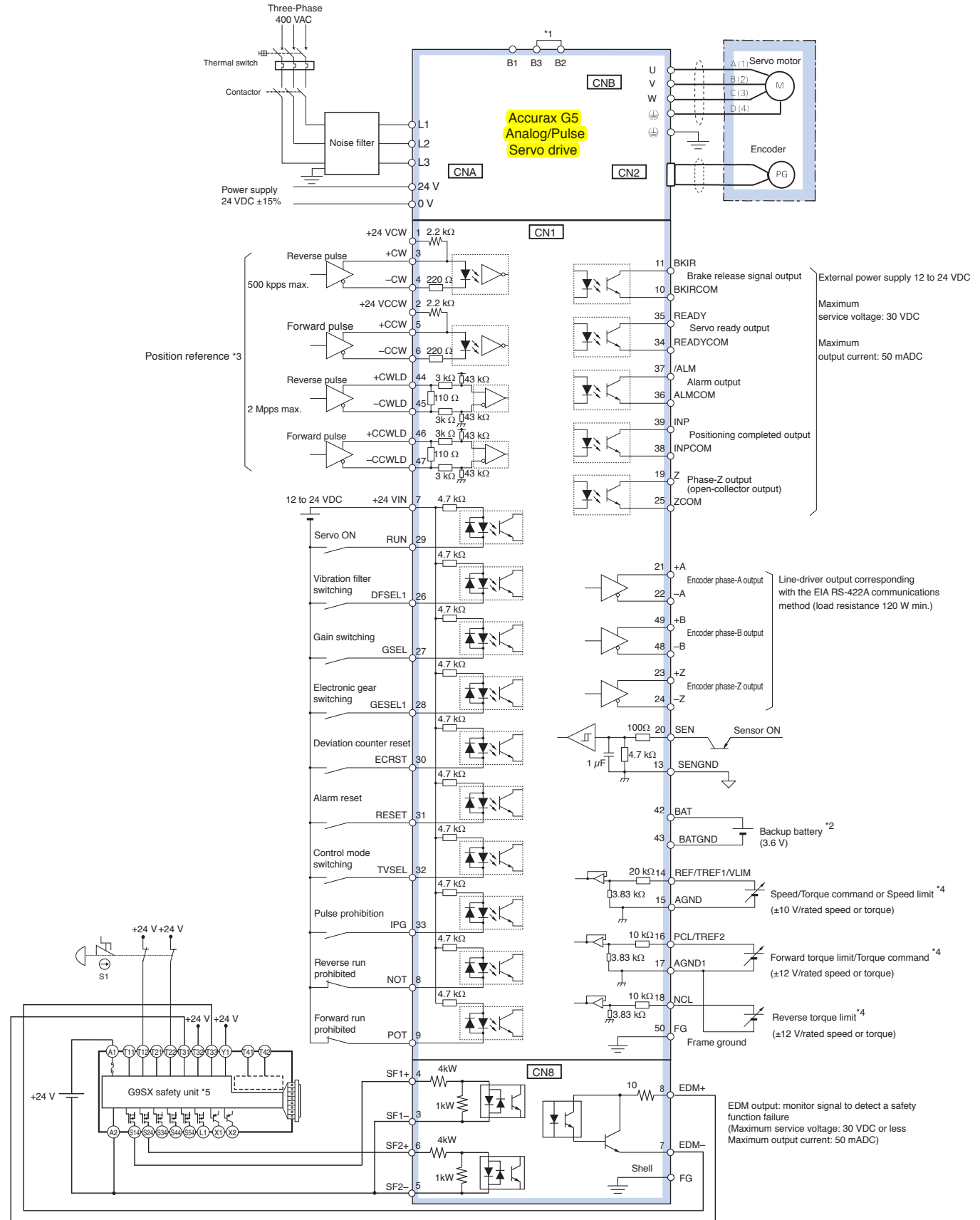

\*1 Normally B2 and B3 are short-circuited. If the internal regenerative resistor is insufficient, remove the wire between B2 and B3 and connect an external regenerative resistor between B1 and B2.  
 \*2 For use only with an absolute encoder. If a backup battery is connected to CN1 I/O connector, an encoder cable with a battery is not required.  
 \*3 Only available in Position control mode.  
 \*4 The input function depends on control mode used (Position, speed or torque control).  
 \*5 Wiring diagram example using the G9SX safety unit. If a safety unit is not used, keep the factory safety bypass connector installed in the CN8.

**Note:** The input function of pins 8,9 and 26 to 33, and output function of pins 10, 11, 34, 35, 38 and 39, can be changed via parameter settings.

Single-phase, 230 VAC

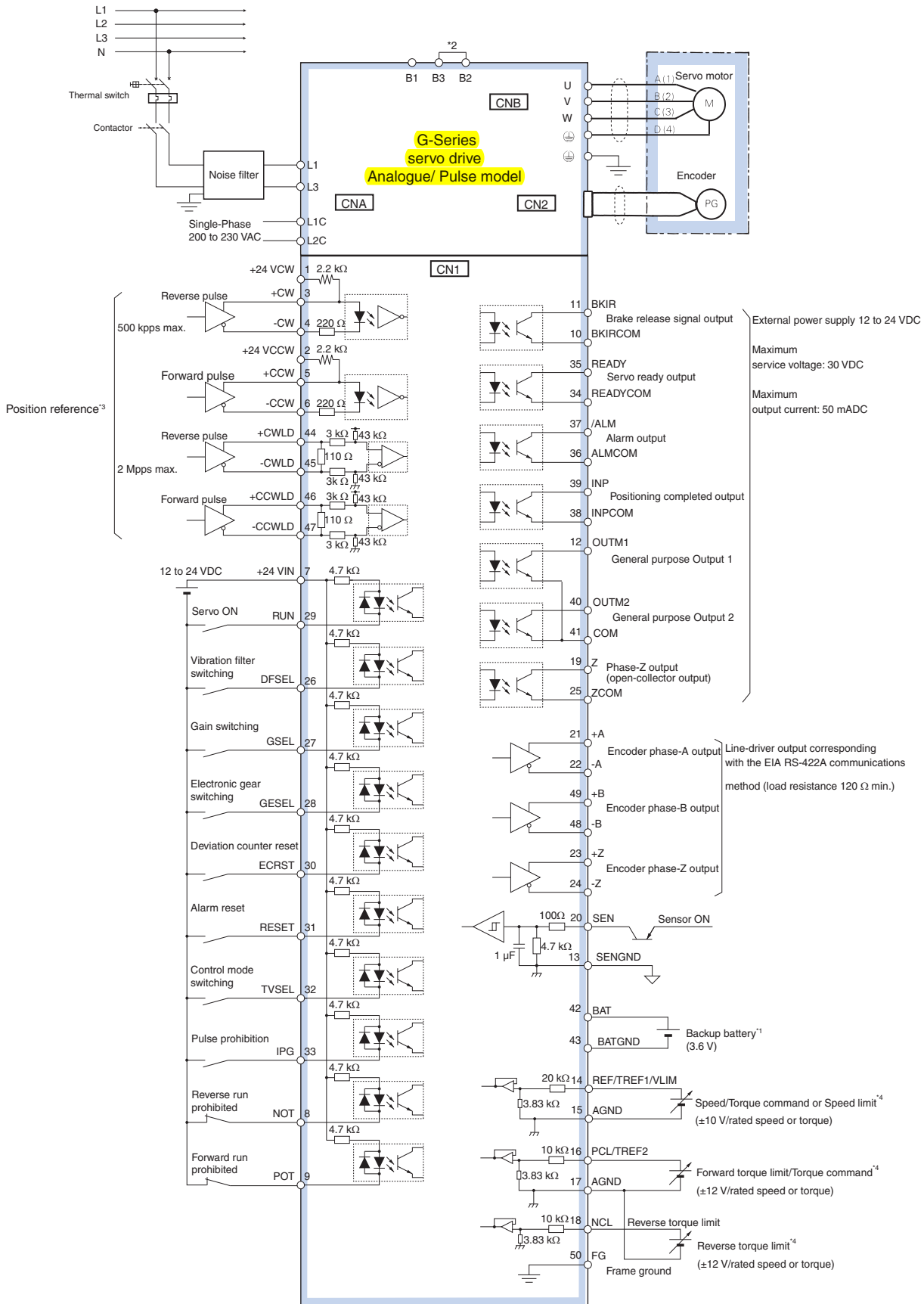

\*1 For use only with an absolute encoder. If a backup battery is connected to CN1 I/O connector, an encoder cable with a battery is not required.  
 \*2 For servo drives from 750 W, B2 and B3 are short-circuited. If the internal regenerative resistor is insufficient, remove the wire between B2 and B3 and connect an external resistor between B1 and B2.  
 \*3 Only available in Position control mode.  
 \*4 The input function depends on control mode used (Position, speed or torque control).

Ordering information

G-Series Analog/pulse model reference configuration

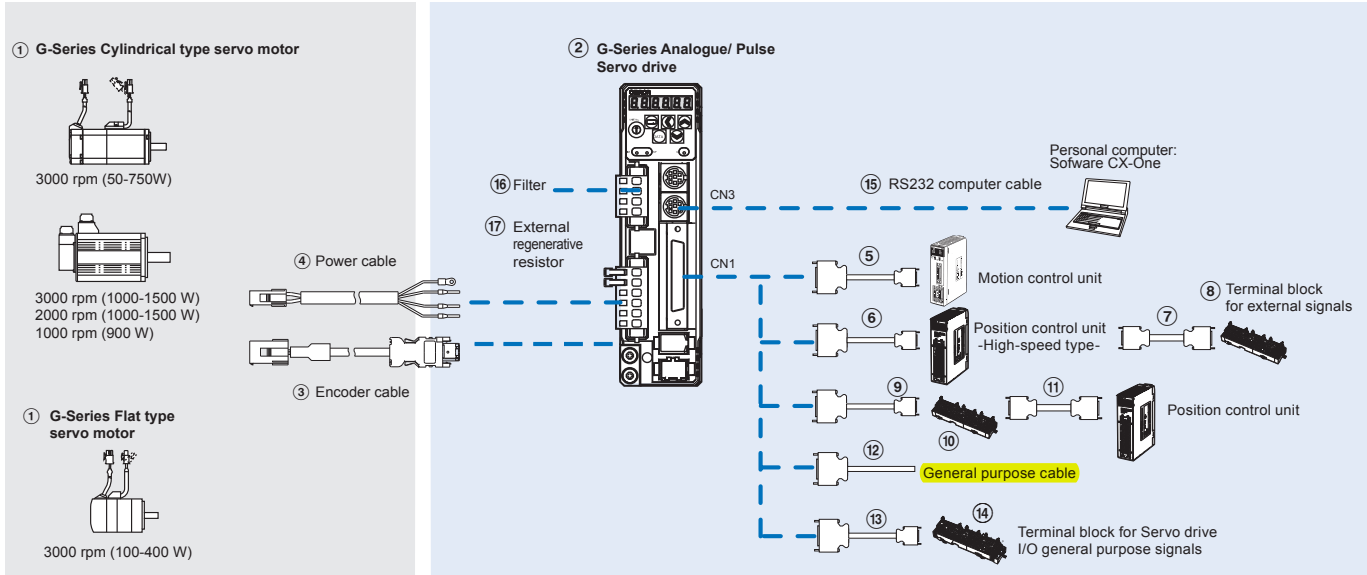

Note: The symbols ①②③④⑤... show the recommended sequence to select the components in a G-Series servo system

Servo motors, power & encoder cables

Note: ①③④ Refer to the G-Series servo motor chapter for servomotor, motor cables or connectors selection

Servo drives

Specifications	Servo drive model	① Compatible rotary servo motors		
		Cylindric type	Flat type	
② 1 phase 200 VAC	100 W	R88D-GT01H	R88M-G05030□ R88M-G10030□	R88M-GP10030□
	200 W	R88D-GT02H	R88M-G20030□	R88M-GP20030□
	400 W	R88D-GT04H	R88M-G40030□	R88M-GP40030□
	750 W	R88D-GT08H	R88M-G75030□	-
	1.0 kW	R88D-GT10H	R88M-G1K020T□	-
	1.5 kW	R88D-GT15H	R88M-G90010T□	-
			R88M-G1K030T□	-
			R88M-G1K520T□ R88M-G1K530T□	- -

Control cables (for CN1)

Symbol	Description	Connect to	Model	
⑤	Control cable (1 axis)	Motion control units CS1W-MC221 CS1W-MC421	1 m	R88A-CPG001M1
			2 m	R88A-CPG002M1
			3 m	R88A-CPG003M1
			5 m	R88A-CPG005M1
	Control cable (2 axis)	Motion control units CS1W-MC221 CS1W-MC421	1 m	R88A-CPG001M2
2 m			R88A-CPG002M2	
3 m			R88A-CPG003M2	
5 m			R88A-CPG005M2	
⑥	Control cable (line-driver output for 1 axis)	Position control units (high-speed type) CJ1W-NC234 CJ1W-NC434	1 m	XW2Z-100J-G9
			5 m	XW2Z-500J-G9
			10 m	XW2Z-10MJ-G9
	Control cable (open-collector output for 1 axis)	Position control units (high-speed type) CJ1W-NC214 CJ1W-NC414	1 m	XW2Z-100J-G13
			3 m	XW2Z-300J-G13
	Control cable (line-driver output for 2 axis)	Position control units (high-speed type) CJ1W-NC234 CJ1W-NC434	1 m	XW2Z-100J-G1
			5 m	XW2Z-500J-G1
			10 m	XW2Z-10MJ-G1
Control cable (open-collector output for 2 axis)	Position control units (high-speed type) CJ1W-NC214 CJ1W-NC414	1 m	XW2Z-100J-G5	
		3 m	XW2Z-300J-G5	

Symbol	Description	Connect to	Model	
⑦	Terminal block cable for external signals (for input common, forward/reverse run prohibited inputs, emergency stop input, origin proximity input and interrupt input)	Position control units (high-speed type) CJ1W-NC234 CJ1W-NC434 CJ1W-NC214 CJ1W-NC414	0.5 m	XW2Z-C50X
			1 m	XW2Z-100X
			2 m	XW2Z-200X
			3 m	XW2Z-300X
			5 m	XW2Z-500X
			10 m	XW2Z-010X
⑧	Terminal block for external signals (M3 screw, pin terminals)		-	XW2B-20G4
	Terminal block for ext. signals (M3.5 screw, fork/round terminals)		-	XW2B-20G5
	Terminal block for ext. signals (M3 screw, fork/round terminals)		-	XW2D-20G6
⑨	Cable from servo relay unit to servo drive	CS1W-NC1□3, CJ1W-NC1□3, C200HW-NC113, CS1W-NC2□3/4□3, CJ1W-NC2□3/4□3, C200HW-NC213/413, CQM1H-PLB21 or CQM1-CPU43	1 m	XW2Z-100J-B25
			2 m	XW2Z-200J-B25
		CJ1M-CPU21/22/23	1 m	XW2Z-100J-B31
			2 m	XW2Z-200J-B31
⑩	Servo relay unit	Position control units CS1W-NC1□3, CJ1W-NC1□3 or C200HW-NC113	-	XW2B-20J6-1B (1 axis)
		Position control units CS1W-NC2□3/4□3, CJ1W-NC2□3/4□3 or C200HW-NC213/413	-	XW2B-40J6-2B (2 axes)
		CQM1H-PLB21 or CQM1-CPU43	-	XW2B-20J6-3B (1 axis)
		CJ1M-CPU21/22/23	-	XW2B-20J6-8A (1 axis) XW2B-40J6-9A (2 axes)
⑪	Position control unit connecting cable	CQM1H-PLB21 or CQM1-CPU43	0.5 m	XW2Z-050J-A3
			1 m	XW2Z-100J-A3
		CS1W-NC113 or C200HW-NC113	0.5 m	XW2Z-050J-A6
			1 m	XW2Z-100J-A6
		CS1W-NC213/413 or C200HW-NC213/413	0.5 m	XW2Z-050J-A7
			1 m	XW2Z-100J-A7
		CS1W-NC133	0.5 m	XW2Z-050J-A10
			1 m	XW2Z-100J-A10
		CS1W-NC233/433	0.5 m	XW2Z-050J-A11
			1 m	XW2Z-100J-A11
		CJ1W-NC113	0.5 m	XW2Z-050J-A14
			1 m	XW2Z-100J-A14
		CJ1W-NC213/413	0.5 m	XW2Z-050J-A15
			1 m	XW2Z-100J-A15
		CJ1W-NC133	0.5 m	XW2Z-050J-A18
			1 m	XW2Z-100J-A18
CJ1W-NC233/433	0.5 m	XW2Z-050J-A19		
	1 m	XW2Z-100J-A19		
CJ1M-CPU21/22/23	0.5 m	XW2Z-050J-A33		
	1 m	XW2Z-100J-A33		
⑫	General purpose cable	For general purpose controllers	1 m	R88A-CPG001S
			2 m	R88A-CPG002S
⑬	Terminal block cable	For general purpose controllers	1 m	XW2Z-100J-B24
			2 m	XW2Z-200J-B24
⑭	Terminal block (M3 screw and for pin terminals)		-	XW2B-50G4
	Terminal block (M3.5 screw and for fork/round terminals)		-	XW2B-50G5
	Terminal block (M3 screw and for fork/round terminals)		-	XW2D-50G6

Computer cable (for CN3)

Symbol	Name		Model
⑮	Computer cable RS232	2 m	R88A-CCG002P2

Connectors

Specifications	Model
I/O connector kit, 50 pins (for CN1)	R88A-CNU11C

Filters

Symbol	Applicable servodrive	Filter model	Rated current	Leakage current	Rated voltage
⑯	R88D-GT01H	R88A-FIK102-RE	2.4 A	3.5 mA	250 VAC single-phase
	R88D-GT02H				
	R88D-GT04H	R88A-FIK104-RE	4.1 A	3.5 mA	
	R88D-GT08H	R88A-FIK107-RE	6.6 A	3.5 mA	
	R88D-GT10H	R88A-FIK114-RE	14.2 A	3.5 mA	
	R88D-GT15H				

Computer software

Specifications	Model
Configuration and monitoring software tool for servo drives and inverters. (CX-drive version 1.70 or higher)	CX-drive
Complete OMRON software package including CX-drive. (CX-One version 3.10 or higher)	CX-One

External regenerative resistor

Symbol	Regenerative resistor unit model	Specifications
⑰	R88A-RR08050S	50 Ω, 80 W
	R88A-RR080100S	100 Ω, 80 W
	R88A-RR22047S	47 Ω, 220 W
	R88A-RR50020S	20 Ω, 500 W